



# Endodontic Obturation Devices

## User Manual



Read this Operation carefully before use.

Keep this User Manual for future reference.



Thank you very much for choosing the Endodontic Obturation Devices of FANTA DENTAL

- To give full play to the function of this device, and operate and maintain it correctly and safely, please read this User Manual carefully before using it, and keep this User Manual properly for reference at any time

**Classification of device safety level:**

- Classification of electric shock protection type: Class II, Internal electrical power source device
- Classification of electric shock protection level: Type B applied part
- Classification of liquid entry prevention level: IPX0
- Sterilization or disinfection method: refer to sterilization part in the manual
- Classified by the safety level in the case of using the product with flammable anesthetic gas mixed with air or flammable anesthetic gas mixed with oxygen or nitrous oxide: not to be used in the case of using the product with flammable anesthetic gas mixed with air or flammable anesthetic gas mixed with oxygen or nitrous oxide
- Classification by mode of operation: Continuous operation
- Software release version:1.0

## Contents

1. Product Introduction .....	1
1.1 Brief Introduction .....	1
1.2 Model .....	1
1.3 Intended use, user, patient .....	1
1.4 Contraindications .....	1
1.5 Precaution and warning .....	1
1.6 Performance characteristics .....	2
1.7 Clinical benefit .....	2
1.8 Contact information .....	2
2. Product Components .....	4
2.1 External Structure of Main Frame of Product .....	4
2.2 Main Accessories of Product .....	4
2.3 Accessories List .....	5
3. User Interface .....	6
3.1 Structure and Description of Main Frame .....	6
3.2 LCD .....	7
4. Product Installation .....	8
4.1 Installation of Filling needle .....	8
4.2 Installation of Silicone case .....	9
4.3 Pre-bending of Filling needle .....	9
4.4 Installation of Extrusion rod and Gutta Percha .....	10
4.5 Installation/Replacement of Extrusion rod Piston .....	11
4.6 Removal of Filling needle .....	11
5. Product Use .....	12
5.1 Operation .....	12
5.2 Charging .....	13
6. Trouble shooting .....	14
7. Cleaning, Disinfection and Sterilization .....	15
8. Storage, Maintenance and Transportation .....	18
8.1 Storage .....	18
8.2 Maintenance .....	18
8.3 Transportation .....	20
9. Technical Parameters .....	21
10. Symbol instruction .....	22
11. Environmental Protection .....	23
12. After-sales Service .....	23
13. EMC Declaration .....	23
Warranty Card .....	30

# **1. Product Introduction**

## **1.1 Brief Introduction**

Endodontic Obturation Devices (hereinafter referred to as “eFiller” or “device” ) is an instrument for injecting the softened and melted gutta percha into the root canal after heating. It can quickly and accurately perform three–dimensional root canal filling, thus making root canal treatment safer, more efficient, faster, and more thorough.

## **1.2 Model**

Model: eFiller

## **1.3 Intended use, user, patient**

1.3.1 Intended use: It is used for root canal filling during root canal treatment.

1.3.2 Intended user: Dentist.

1.3.3 Intended patient: People who need root canal shaping and cleaning, and root canal shape is good.

1.3.4 Use place: hospital or dental clinic.

## **1.4 Contraindications**

None

## **1.5 Precaution and warning**

Please read the following warnings before use:

- It is contraindicated by hemophiliacs, patients with cardiac pacemaker or cochlear implant and doctors;
- It should be used with caution on patients with heart disease, pregnant women and young children;
- Do not perform any dental operations other than root canal filling;
- Do not use this device in the presence of free oxygen, flammable anesthetic mixtures or flammable substances;
- This device shall not be placed in a humid environment or any place where it may come into contact with any type of liquid;
- Patients are at risk of thermal hazards;
- Do not expose this device to direct or indirect heat source. This device must be operated and stored in a safe environment;
- With regard to electromagnetic compatibility (EMC), this device requires special precautions and must be installed and operated in strict accordance

with EMC information. In particular, this device should not be used near fluorescent amplifiers, radio transmitter remote controls, portable or movable communication devices, nor should it be charged, operated or stored at high temperatures. This device shall comply with the specified operating and storage conditions;

- Please use disposable gloves and rubber dam during treatment;
- If the device is abnormal during the treatment, please turn it off and then contact the local distributor or manufacturer;
- Please do not disassemble and repair this device without permission, otherwise it may automatically lose the warranty qualification;
- Please be sure to use the original accessories, such as Filling needle and Power adapter;
- When the operator is in use (including charging), do not place it in a location where it is difficult to disconnect the power, when it is dangerous.

## **1.6 Performance characteristics**

### **1.6.1 Appearance and structure:**

The appearance of the Endodontic Obturation Devices should be easy to clean, the shell should have no edges, burrs and cracks, and the plastic parts should have no foaming, cracking and deformation. The panel of the Endodontic Obturation Devices shall be free of coating shedding or rust, and the text and marks on the panel shall be clearly visible.

1.6.2 The heating function of the Endodontic Obturation Devices shall meet the following requirements:

Short press the switch/temperature setting button to adjust the temperature of 6 levels, adjustable temperature: 100°C, 120°C, 140°C, 170°C, 200°C, 230°C;

## **1.7 Clinical benefit**

The performance of Endodontic Obturation Devices has been fully identified and evaluated, the product can meet the clinical intended use, and the related risks have been fully evaluated, and the residual risks are acceptable.

## **1.8 Contact information**

Website: [www.fanta-dental.com](http://www.fanta-dental.com)

After launch of European Database on Medical Devices/EUDAMED, the summary of safety and clinical performance will be made available to the public at <https://ec.europa.eu/tools/eudamed>.

Basic UDI-DI: 697107537eFillerYG

For a patient/user/third party in the European Union and in countries with identical regulatory regime(Regulation 2017/745/EU on Medical Devices); if, during the use of this device or as a result of its use, a serious incident has occurred, please report it to the manufacturer and/or its authorized representative and to your national authority.

The contacts of national competent authorities (Vigilance Contact Points) and further information can be found on the following European Commission website:

[https://ec.europa.eu/growth/sectors/medical-devices/contacts\\_en](https://ec.europa.eu/growth/sectors/medical-devices/contacts_en)

- a) name of manufacturer or distributor;
- b) type of instruments, product identification;
- c) product size;

Complete Contraindications, Warnings and Precautions will be available and kept up to date on the IFU.

For additional information, contact your Fanta Dental Sales Representative or Shanghai Fanta Dental Materials Co., LTD. Customer Service. No electronic version of the IFU provided.

## 2. Product Components

### 2.1 External Structure of Main Frame of Product

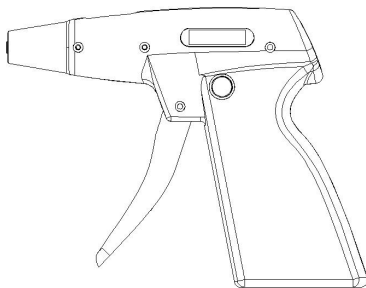

### 2.2 Main Accessories of Product



Filling needle



Wrench



Snap ring

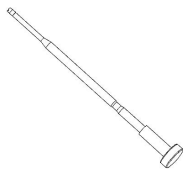

Extrusion rod



Cleaning brush

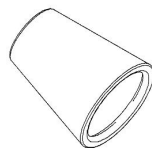

Silicone case

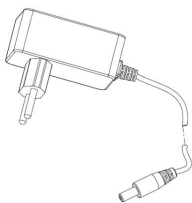

Power adapter

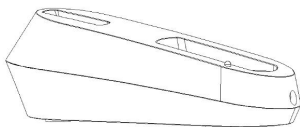

Charging base

### 2.3 Accessories List

Components	Type	No.
Main Frame	eFiller	1
Filling needle	BMFN0001 (23G)	2
	BMFN0002 (25G)	2
Wrench	BMWH0001	1
Extrusion rod	BMER0001	1
Cleaning brush	BMCB1001	1
Snap ring	BMSR0001	1
Silicone case	BMSC0001	3
Power adaptor	UES12LCP-050200SPA	1
Charging base	BMCB0004	1

If the user wants to purchase an additional accessory, he or she needs to contact the local designated dealer or manufacturer, and can't change the accessory at will, otherwise the risk is not acceptable.

### 3. User Interface

#### 3.1 Structure and Description of Main Frame

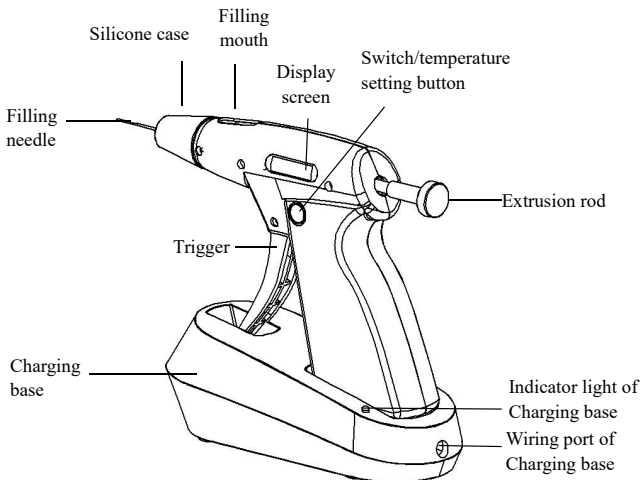

**Filling needle:** after heating and softening, the gutta percha flows out from the Filling needle;

**Silicone case:** it is used to prevent scald caused by heating during operation. Please be sure to install the Silicone case before operation;

**Extrusion rod:** it is used to push the gutta percha into the heating chamber;

**Trigger:** pull the trigger for gutta percha filling;

**Wiring port of Charging base:** the connection port between the USB cable and the Charging base for charging;

**Display screen:** display the preset temperature, real-time temperature and battery power, as detailed in 3.2.

**Switch/temperature setting button:**

- Start the device: press and hold this button to start the device and start heating.
- Adjust the temperature: under startup state, press this button to adjust the

preset temperature. The adjustable temperature range includes 100°C, 120°C, 140°C, 170°C, 200°C and 230°C;

- Close the device: press and hold this button to shut down the device and stop heating.

#### **Indicator light of Charging base:**

- When the Charging base is powered on, the indicator light is always on in green;
- When the main frame is placed on the Charging base to charge, the indicator light is always on in blue;
- When the main frame is fully charged, the indicator light is always on in green;

### **3.2 LCD**

② Device state indicator

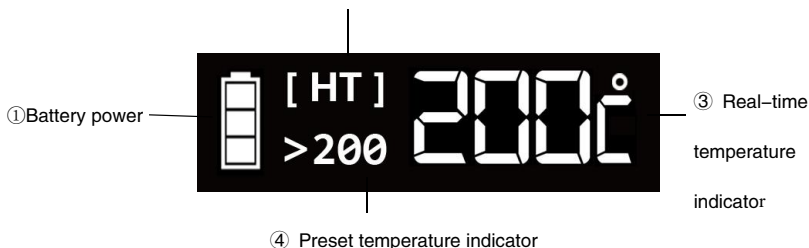

#### **① Battery power display:**



: 60–100% battery power;



: 40–60% battery power;



: 10–40% battery power;



: 0–10% battery power.

The battery runs down. Please charge the device right away.

#### **② Device state indicator:**

- [ DR ] —— standby state: the device is ready to enter the standby mode;  
[ HT ] —— heating state: the device is heated;  
[ CD ] —— cooling state: the device is cooled;  
[ CT ] —— constant temperature state: When reach the preset temperature device will enter into the constant temperature mode;  
[ E0 ] / [ E1 ] —— Error state: See Section 6 Troubleshooting for details.

**③ Real-time temperature indicator:**

Display real-time temperature

**④ Preset temperature indicator:**

The temperature is adjustable, and the adjustable range include 100°C, 120°C, 140°C, 170°C, 200°C and 230°C;

## 4. Product Installation

### 4.1 Installation of Filling needle

Align the thread on the Filling needle with the stud on the main frame, insert them together to make sure the thread matches correctly, and rotate gently clockwise.

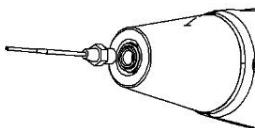

Align the wrench with the slot of the Filling needle, rotate the wrench clockwise, and slowly apply force until the Filling needle is tightened.

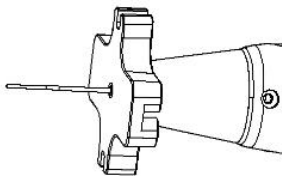

**Warning:**

- When installing the Filling needle, please ensure that the main frame is powered off;
- Before inserting the Filling needle, check the assembly interface between the Filling needle and the main frame. Please do not use the damaged Filling needle or device;
- When the Filling needle is installed on the main frame, it will not become loose or fall off to ensure that the Filling needle is firmly installed;
- If the Filling needle is not firmly installed, it may lead to unpredictable rotation or the Filling needle may fall off, and even hurt the patient;
- Please use the original Filling needle;
- The Filling needle has not been disinfected and sterilized when they leave the factory. Please clean, disinfect and sterilize the Filling needle before each treatment.

#### 4.2 Installation of Silicone case

Align the Silicone case with the head and gently put it on.

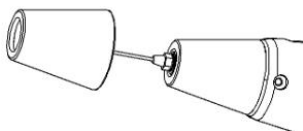

#### 4.3 Pre-bending of Filling needle

Pre-bend the Filling needle according to the treatment needs, as shown in the figure below.

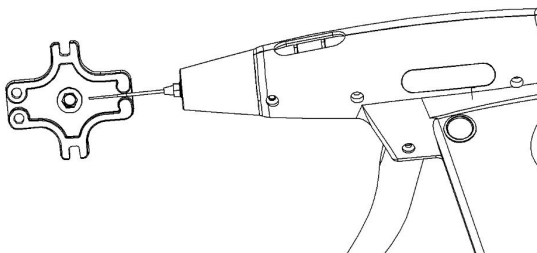

#### 4.4 Installation of Extrusion rod and Gutta Percha

Before inserting the gutta percha, the Extrusion rod only needs to be pushed into the edge of the filling mouth, as shown in the figure below.

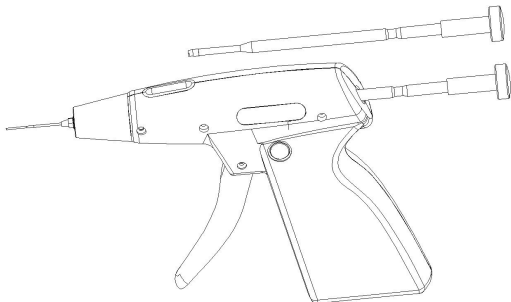

Install the gutta percha: tilt the head of eFiller downward slightly and put the gutta percha into the filling mouth.

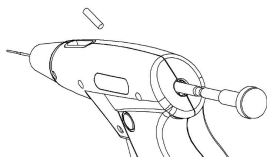

#### **Warning:**

Gently push the Extrusion rod with your hand or pull the trigger to push the gutta percha into the heating chamber. When the gutta percha is completely pushed into the heating chamber, the Extrusion rod is approximately located as shown in the figure below.

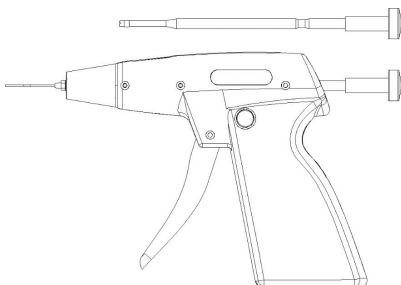

#### 4.5 Installation/Replacement of Extrusion rod Piston

Use a straight screwdriver to unscrew the screws and replace the piston of the Extrusion rod.

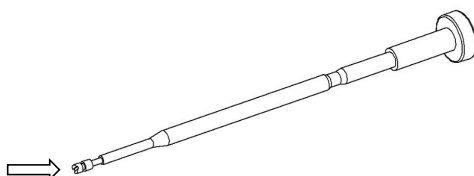

#### Caution:

- The piston of the Extrusion rod is a fragile and consumable part. Its wear or damage may cause the gutta percha to flow back into the filling mouth. Please check whether it is in good condition before use.
- The piston of the Extrusion rod should not be installed too tight, otherwise its service life may be shortened.

#### 4.6 Removal of Filling needle

Align the wrench with the slot of the Filling needle, rotate the wrench counterclockwise to loosen the Filling needle, and continue to rotate the wrench until the Filling needle comes out.

#### Caution:

The Filling needle is for one-time use and secondary use is prohibited.



**Warning:**

- When installing or removing the Filling needle, please be careful not to injure your finger;
- When installing or removing the Filling needle, please make sure the main frame stops working.

## 5. Product Use

### 5.1 Operation

**Start the device:** press and hold the switch/temperature setting button of the device, accompanied by a prompt tone, the device is started for heating, and the preset temperature can be reached after heating about 25s.

**Adjust the temperature:** under startup state, press the switch/temperature setting button of the device to adjust the preset temperature. The adjustable temperature range include 100℃, 120℃, 140℃, 170℃, 200℃ and 230℃.

**Close the device:** press and hold the switch/temperature setting button of the device, accompanied by a prompt tone, the device will shut down and stop heating.

**Automatic shutdown:** when the device is not operated for more than 10 minutes, it will automatically shut down.



**Warning:**

- Before each use of the wrench, Filling needle and Silicone case, they need to be disinfected and sterilized to avoid cross infection;
- When the device does not reach its set temperature, do not pull the trigger, otherwise it may cause damage to the device;
- Before removing the Filling needle, please clean up the gutta percha, and then remove the Filling needle with a wrench. Before using the Filling needle for treatment, please try it outside the mouth to ensure that the device can work normally;
- The power adapter should meet the requirements of the IEC 60601-1 standard. Please use the power adapter and cable provided by the manufacturer for charging;

- Even in normal use, the Filling needle may be separated from the main frame due to metal fatigue and wear. Please replace it in time. Please do not use the Filling needle more than its recommended times of use;
- If the Extrusion rod and the piston of the Extrusion rod are worn or damaged, please replace them in time;
- Please do not disassemble the Filling needle during the treatment, because it may scratch the operator or the patient.



Caution:

- In case of any abnormality, please stop using this device;
- Be sure to remove the Filling needle after each treatment.

## 5.2 Charging

- Insert the USB cable into the Charging base (Figure a);
- When the Power adapter is inserted into the mains socket, the power indicator light of the Charging base is always on in green;
- When the main frame is placed on the Charging base, it enters the charging state, and the power indicator light on the Charging base turns to be always on in blue. When the main frame is fully charged, the power indicator light on the Charging base turns to be always on in green.

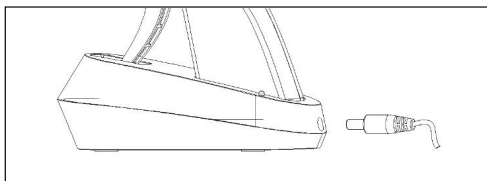

Figure a



Caution:

- When the error code E0 appears, accompanied by a prompt tone, it indicates that the battery power is low and the device should be

charged in time;

- When the main frame is inserted into the Charging base, but it does not enter the charging state, please stop charging it immediately and then contact the local distributor;
- When charging with the Charging base, please place the Charging base or the main frame in a dry and safe place where they are not easily knocked over;
- Please use the power adapter and cable provided by the manufacturer for charging;
- It normally takes about 180 minutes for the device to be fully charged, but that also depends on the battery loss and remaining battery power;
- After the battery is discharged completely, the battery may not be recharged, thus causing it to be damaged. When the device is not used for a long time, it should be fully charged every one to two months;
- Do not place the Charging base or main frame in dust, or especially in the environment with metal debris. Please pay special attention to the protection of charging port.

## 6. Trouble shooting

When a trouble is found, check the following points before contacting your dealer, if none of these apply, Or if the trouble is not resolved even after taking action, the product may fail, contact your distributor business.

<b>Fault phenomenon</b>	<b>Check items</b>	<b>Fault analysis and handling method</b>	<b>Reference chapter or section</b>
The error code E0 appears	The battery power is low.	Charge it in time.	5.2
The error code E1 appears	The heating module is damaged	Contact the manufacturer or supplier	12
Fail to start up	The time to press the switch button is too short	Press and hold the switch button	5.1
The Extrusion rod cannot be	The gutta percha is cooled and solidified in	Open the switch of eFiller, set the temperature at 200℃, wait for the	4.4

pulled out	the heating chamber to fix the Extrusion rod	device to reach the preset temperature, and then pull out the Extrusion rod.	
	If it still cannot be pulled out, check for residual gutta percha	Turn off the power to make eFiller cool down, take out the Filling needle with a wrench, and then pull the trigger to push the Extrusion rod to eject the residual gutta percha.	4.6
The Filling needle is blocked and no gutta percha is flowing out	Check whether the piston of the Extrusion rod is deformed	Check whether the piston of the Extrusion rod is deformed. If it is deformed, replace it in time	4.5
	Check whether the heating chamber is blocked	Remove the Filling needle and push all the gutta percha through the Extrusion rod to empty the heating chamber.	4.4

## 7. Cleaning, Disinfection and Sterilization



### Caution:

- No part of eFiller is sterilized before leaving the factory



### Warning:

- Do not immerse the Main Frame in the ultrasonic cleaner.
- Do not use liquid or spray cleaner directly, especially on the screen.
- Except the Filling needle, wrench and Silicone case, all other parts for the device can't be sterilized by high temperature and pressure. See the following table for the cleaning methods of other parts.
- Do not use any heat, radiation, formaldehyde, ethylene oxide or plasma for sterilization.



### Advice:

- Reprocessing procedures have only limited implications to this dental instruments. The limitation of the numbers of reprocessing procedures is therefore determined by the function / wear of the device. From the processing side there is no maximum number of allowable reprocessing. The device should no longer be reused in case of signs of material degradation.
- In case of damage the device should be reprocessed before sending back to the manufacturer for repair.

### Reprocessing Instructions

Step	Parameter
Preparation at the Point of Use:	Remove gross soiling of the instrument with cold water (<40 °C ) immediately after use. Don' t use a fixating detergent or hot water (>40 °C) as this can cause the fixation of residuals which may influence the result of the reprocessing process. Store the instruments in a humid surrounding, if required.
Transportation:	Safe storage and transportation to the reprocessing area to avoid any damage and contamination to the environment.
Preparation for Decontamination:	The devices must be reprocessed in a disassembled state, as far as possible. Only Filling needle, wrench and Silicone case can be cleaned and disinfected with automated methods and sterilized with steam sterilization process. Do not sterilize the Main Frame, Power adapter and Charging base! The Main Frame, Power adapter and Charging base cannot be cleaned and disinfected in a washer/disinfector! For these parts, only a general wipe decontamination is possible!
Decontamination of other parts than Filling needle, wrench and Silicone case:	After operation, take the Main Frame, Power adapter and Charging base on the workbench. Soak a soft cloth completely with distilled water or deionized water, and wipe all the surfaces of these components, until the surface of the components is visually clean. For decontamination, soak a dry soft cloth with 75% alcohol or other disinfects which are approved for its efficacy by VAH/DGHM–listing, CE marking, FDA and Health Canada Approval. Wipe all surfaces of the Main Frame, Power adapter, Charging base and other components with the wet soft cloth for about 3 minutes. Please follow the instructions of manufacturer of disinfectants. Wipe the surface of the component with a dry soft lint–free cloth.
Following instructions are only relevant for Filling needle, wrench and Silicone case!	
Pre–Cleani	Not use automated cleaning, disinfection and sterilization for other parts

ng of Filling needle, wrench and Silicone case:	than Filling needle, wrench and Silicone case in this system! Do a manual pre-cleaning, until the instruments are visually clean. Submerge the instruments in a cleaning solution and flush the lumens with a water jet pistol with cold tap water for at least 10 seconds. Clean the surfaces with a soft bristle brush.
Cleaning:	Regarding cleaning/disinfection, rinsing and drying, it is to distinguish between manual and automated reprocessing methods. Preference is to be given to automated reprocessing methods, especially due to the better standardizing potential and industrial safety.  Automated Cleaning: Use a washer-disinfector meeting the requirements of the ISO 15883 series. Put the instrument into the machine on a tray. Connect the instrument with the WD by using suitable adapter and start the program: <ul style="list-style-type: none"> <li>● 4 min pre-washing with cold water (&lt;40°C);</li> <li>● emptying</li> <li>● 5 min washing with a mild alkaline cleaner at 55°C</li> <li>● emptying</li> <li>● 3 min neutralising with warm water (&gt;40°C);</li> <li>● emptying</li> <li>● 5 min intermediate rinsing with warm water (&gt;40°C)</li> <li>● Emptying</li> </ul> The automated cleaning processes have been validated by using 0.5% neodisher MediClean forte (Dr. Weigert). Note Acc. to EN ISO 17664 no manual reprocessing methods are required for these devices. If a manual reprocessing method has to be used, please validate it prior to use.
Disinfection :	Automated thermal disinfection in washer/disinfector under consideration of national requirements in regards to A0 value (see EN 15883). A disinfection cycle of 5 min disinfection at 90°C has been validated for the device to achieve an A0 value of > 3000. Here we suggest a disinfection cycle of 5 min disinfection time at 93 °C.
Drying:	Automated Drying: Drying of outside of instrument through drying cycle of washer/disinfector. If needed, additional manual drying can be performed through lint free towel. Insufflate cavities of instruments by using sterile compressed air.
Functional Testing, Maintenanc e:	Visual inspection for cleanliness of the instruments and reassembling, if required. Functional testing according to instructions of use. If necessary, perform reprocessing process again until instrument is visibly clean.

	Before packaging and autoclaving, make sure that these devices have been maintained acc. to manufacturer' s instruction.
Packaging:	Pack the instruments in an appropriate packaging material for sterilization. The packaging material and system refer to EN ISO 11607.
Sterilization :	<p>Sterilization of instruments by applying a fractionated pre–vacuum steam sterilization process (according to EN 285/EN 13060/EN ISO 17665) under consideration of the respective country requirements.  Minimum requirements: 3 min at 134°C (in EU: 5 min at 134°C)  Maximum sterilization temperature: 137°C</p> <p>Drying time:  For steam sterilization, we recommend a drying time of 15 to 40 minutes. Choose a suitable drying time, depending on the autoclave and load. Refer to the autoclave' s instructions for use.</p> <p>After sterilization:</p> <ol style="list-style-type: none"> <li>Remove the product from the autoclave.</li> <li>Let the product cool down at room temperature for at least 30 minutes. Do not use additional cooling.</li> </ol> <p>Check that the sterilization wraps or pouches are not damaged.  Flash sterilization is not allowed on lumen instruments!</p>
Storage:	Storage of sterilized instruments in a dry, clean and dust free environment at modest temperatures, refer to label and instructions for use.
It is the duty of the user to ensure that the reprocessing processes including resources, materials and personnel are capable to reach the required results. State of the art and often national law requiring these processes and included resources to be validated and maintained properly.	

## 8. Storage, Maintenance and Transportation

### 8.1 Storage

- This product should be handled with care, kept away from earthquake source, and stored in a dry and ventilated place.
- This product should not be placed together with toxic, corrosive, flammable and explosive items.
- The relative humidity of the storage environment should be 10%–80%, the atmospheric pressure should be 500–1060hPa, and the temperature should be –10°C~ +50°C.

### 8.2 Maintenance

- This product does not contain self–repair spare and accessory parts. Repair of this product should only be carried out by specialized maintenance personnel or special repair shops.
- Please keep this product dry. Rainwater, moisture and liquids may

contain minerals that can corrode the electronic circuit of this product.

- c. Do not throw, knock or vibrate this product. Rough handling of this product may damage its internal circuit board and wires.
- d. Do not apply paint to this product, as it will leave debris in the removable parts, thus affecting its normal operation.

➤ **Change battery**

The device uses a rechargeable lithium battery. The battery life or number of recharges depends on the usage.

Lithium batteries have no memory effect, so you don't need to care too much about the timing of charging;

The factors that have great influence on battery life include:

a) Long-term storage may cause damage to the battery. It is recommended that the battery should be fully charged once within one month of storage when it is fully charged;

b) Don't charge at the ambient temperature exceeding the requirement. It is recommended that the ambient temperature is less than 40 degrees.

**Battery replacement procedure**

- 1 Open the battery cover

As shown by the arrow on the right, use a screwdriver to unscrew the screws of the battery cover counterclockwise to open the battery cover;

- 2 Remove the old battery

Hold the battery cable (connecting the battery connector part) with your hand, and pull out the battery connector from the motherboard socket;

- 3 Replace with new battery

Put the new battery into the battery compartment, and insert the battery connector into the mother board socket, as shown in the figure on the right.

- 4 Install the battery cover

According to the picture on the right, arrange the battery cables, close the

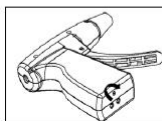
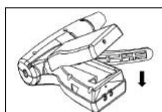
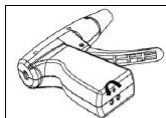

battery cover, and tighten the screws clockwise.



**WARNING:**

- Do not open any parts except the battery compartment on the host;
- Please use the battery provided by the manufacturer, do not use batteries of other specifications to avoid damage;
- Battery specification: 18650 cylindrical lithium battery, rated voltage 3.6V;
- If the battery is leaking or swollen, stop using it immediately;
- Do not use any damp cloth, alcohol, or other chemical reagents to wipe the surface of the battery;
- When replacing the battery, please keep your hands dry and free of water droplets; liquids can cause a short circuit of the battery, damage the device, and even cause the battery to catch fire, etc.;
- If battery liquid enters the eye area, immediately rinse with water and go to the hospital for treatment.























### **8.3 Transportation**

- a. During the transportation, excessive impact and vibration should be prevented. Handle it with care. placing it upside down should be avoided.
- b. This product should not be transported together with dangerous goods.
- c. This product should not be exposed to the sun, rain or snow during transportation.

## 9. Technical Parameters

Manufacturer	Changzhou Bomedent Medical Technology Co., Ltd.
Product name	Endodontic Obturation Devices
Model	eFiller
Dimensions	Main frame: 145*30*120mm Charging base: 152*57*52mm
Packing weight	870g
Power supply mode	Lithium battery, DC 3.6V, 2600mAh
Charging base	Input: DC5V/2A Output: DC 3.6V, 2600mAh
Power adapter	Input: AC100–240V, 50/60Hz 0.5A Output: DC5V/2A
Liquid permeation protection	IPX0
Classification of electric shock protection type	Class II, Internal power unit
Classification of electric shock protection level	Class B
Heating temperature	100℃、120℃、140℃、170℃、200℃、230℃
Use environment	Temperature: 10–40℃ Humidity: 10–70% Atmospheric pressure: 700–1060hPa
Storage/transportation environment:	Temperature: –10–50℃ Humidity: 10–80% Atmospheric pressure: 500–1060hPa
Expected service life	4 years

## 10. Symbol instruction

	General warning sign		Refer to the Operation Manual
	Type B applied part		Class II equipment
	Direct current		Serial number
	Manufacturer		Date of manufacture
	For indoor use only		This way up
	Keep dry		Fragile, handle with care
	Washer-disinfector for thermal disinfection		Sterilizable in a steam sterilizer (autoclave) at the temperature specified
	Temperature limitation		Humidity limitation
	Atmospheric pressure limitation		Follow the waste of electric and electronic equipment (WEEE) Directive
	This conforms to CE European Directive of "Medical equipment directive 93/42/EEC" .		Authorized representative in the European Community
	Catalogue number		Medical device
	Unique Device Identifier		

## 11. Environmental Protection

This product does not contain harmful ingredients and can be disposed and destroyed according to the relevant local regulations.

## 12. After-sales Service

The manufacturer provides quality assurance to the purchaser of the product due to quality problems caused by the product's own materials and workmanship during normal installation and use. The host and reducer are guaranteed for 1 year free of charge, and consumables such as batteries and accessories are not covered by the warranty. If the battery and accessories are damaged, please use the battery and accessories provided by the manufacturer. The maintenance of the components needs to be repaired by professional personnel. Please refer to "Warranty Card" for the warranty period and manufacturer details.

If the maintenance personnel need to use the circuit diagram, our company will provide it.

## 13. EMC Declaration

Guidance and Manufacturer' s Declaration

Below cables information are provided for EMC reference.

Cable	Max. cable length, Shielded/unshielded		Number	Cable classification
	Shielded	Unshielded		
DC Power Line (USB Cable)	1.5m	Unshielded	1 Set	DC Power

### Important information regarding Electro Magnetic Compatibility (EMC)

This electrical medical equipment needs special precautions regarding EMC and put into service according to the EMC information provided in the user manual; the equipment conforms to this IEC 60601-1-2:2014 standard for both immunity and emissions. Nevertheless, special precautions need to be observed:

The equipment with no ESSENTIAL PERFORMANCE is intended used in Professional healthcare facility environment except for near active HF SURGICAL EQUIPMENT and the RF shielded room of an ME SYSTEM for magnetic resonance imaging, where the intensity of EM DISTURBANCES is high.

WARNING: Use of this equipment adjacent to or stacked with other equipment should be avoided because it could result in improper operation. If such use is necessary, this equipment and the other equipment should be observed to verify that they are operating normally” .

The use of accessories, transducers and cables other than those specified or provided by the manufacturer of this equipment could result in increased electromagnetic emissions or decreased electromagnetic immunity of this equipment and result in improper operation.

WARNING: Portable RF communications equipment (including peripherals such as antenna cables and external antennas) should be used no closer than 30 cm (12 inches) to any part of the equipment, including cables specified by the manufacturer. Otherwise, degradation of the performance of this equipment could result.”

WARNING: If the use location is near (e.g. less than 1.5 km from) AM, FM or TV broadcast antennas, before using this equipment, it should be observed to verify that it is operating normally to assure that the equipment remains safe with regard to electromagnetic disturbances throughout the expected service life.

## EMI Compliance Table (Table 1)

**Table 1 – Emission**

<b>Phenomenon</b>	<b>Compliance</b>	<b>Electromagnetic environment</b>
RF emissions	CISPR 11 Group 1, Class B	Professional healthcare facility environment
Harmonic distortion	IEC 61000–3–2 Class A	Professional healthcare facility environment
Voltage fluctuations and flicker	IEC 61000–3–3 Compliance	Professional healthcare facility environment

## EMS Compliance Table (Table 2–5)

### Table 2 – Enclosure Port

Phenomenon	Basic EMC standard	Immunity test levels
		Professional healthcare facility environment
Electrostatic Discharge	IEC 61000–4–2	± 8 kV contact ± 2kV, ± 4kV, ± 8kV, ± 15kV air
Radiated RF EM field	IEC 61000–4–3	3V/m 80MHz–2.7GHz 80% AM at 1kHz
Proximity fields from RF wireless communications equipment	IEC 61000–4–3	Refer to table 3
Rated power frequency magnetic fields	IEC 61000–4–8	30A/m 50Hz or 60Hz

### Table 3 – Proximity fields from RF wireless communications equipment

Test frequency (MHz)	Band (MHz)	Immunity test levels
		Professional healthcare facility environment
385	380–390	Pulse modulation 18Hz, 27V/m
450	430–470	FM, ± 5kHz deviation, 1kHz sine, 28V/m
710	704–787	Pulse modulation 217Hz, 9V/m
745		
780		
810		
870	800–960	Pulse modulation 18Hz, 28V/m
930		
1720		
1845	1700–1990	Pulse modulation 217Hz, 28V/m
1970		
2450	2400–2570	Pulse modulation 217Hz, 28V/m
5240	5100–5800	Pulse modulation 217Hz, 9V/m
5500		
5785		

**Table 4 – Input a.c. power Port**

Phenomenon	Basic EMC standard	Immunity test levels
		Professional healthcare facility environment
Electrical fast transients/burst	IEC 61000–4–4	± 2 kV 100kHz repetition frequency
Surges Line-to-line	IEC 61000–4–5	± 0.5 kV, ± 1 kV
Surges Line-to-ground	IEC 61000–4–5	± 0.5 kV, ± 1 kV, ± 2 kV
Conducted disturbances induced by RF fields	IEC 61000–4–6	3V, 0.15MHz–80MHz 6V in ISM bands between 0.15MHz and 80MHz 80%AM at 1kHz
Voltage dips	IEC 61000–4–11	0% U <sub>i</sub> ; 0.5 cycle At 0°, 45°, 90°, 135°, 180°, 225°, 270° and 315°
		0% U <sub>i</sub> ; 1 cycle and 70% U <sub>i</sub> ; 25/30 cycles Single phase: at 0°
Voltage interruptions	IEC 61000–4–11	0% U <sub>i</sub> ; 250/300 cycles

**Table 5 – Signal input/output parts Port**

Phenomenon	Basic EMC standard	Immunity test levels
		Professional healthcare facility environment
Conducted disturbances induced by RF fields	IEC 61000–4–6	3V, 0.15MHz–80MHz 6V in ISM bands between 0.15MHz and 80MHz 80%AM at 1kHz







## Warranty Card

**Dear user:**

**For the warranty:**

1. We offer 1 year warranty for the product eFiller(excluding the accessories).
2. The following circumstance does not belong to the scope of free warranty:
  - a) Using the product did not follow the matters needing attentions in user's manual;
  - b) Disassembling the product by yourself;
  - c) Altering the invoice or without the invoice.
3. Fill up the following information, then send it back to us with our products.

User' s Name: \_\_\_\_\_

Telephone Number: \_\_\_\_\_

Address: \_\_\_\_\_

\_\_\_\_\_

\_\_\_\_\_

Trouble Description:

\_\_\_\_\_

\_\_\_\_\_

\_\_\_\_\_

\_\_\_\_\_

(The information such as: When, Where and How it happened. How many times)

Shanghai Fanta Dental Materials Co., Ltd.

Room 1305, Building 14, No.655 Road Fengzhou, District Jiading, 201801 Shanghai, China.

Website:www.fanta-dental.com





ChangZhou BoMedent Medical Technology Co.,Ltd.  
No.9 Changyang Road, West Taihu Science and Technology  
Industrial Park, Changzhou 213000 Jiangsu P.R. China



Caretechion GmbH  
Niederrheinstr. 71, 40474 Duesseldorf, Germany

Document Number: RD-DZ-RCF-SM-002

Version number: B/0

Date of revision: 2024-11-27